



# ASSASSIN Assembly Instructions

**IMPORTANT INFORMATION. READ CAREFULLY. KEEP THIS INFORMATION FOR FUTURE REFERENCE.**

These instructions are for assembly of your new Excalibur crossbow only, please refer to your Owner's Manual for information on how to use, care for and maintain your Excalibur crossbow. **NOTE: IMAGES MAY NOT BE EXACTLY AS PRODUCED, THEY HAVE BEEN MODIFIED FOR INSTRUCTIONAL PURPOSES.**

## ASSEMBLING YOUR ASSASSIN CROSSBOW IS EASY

### Step 1: Remove all parts from the box

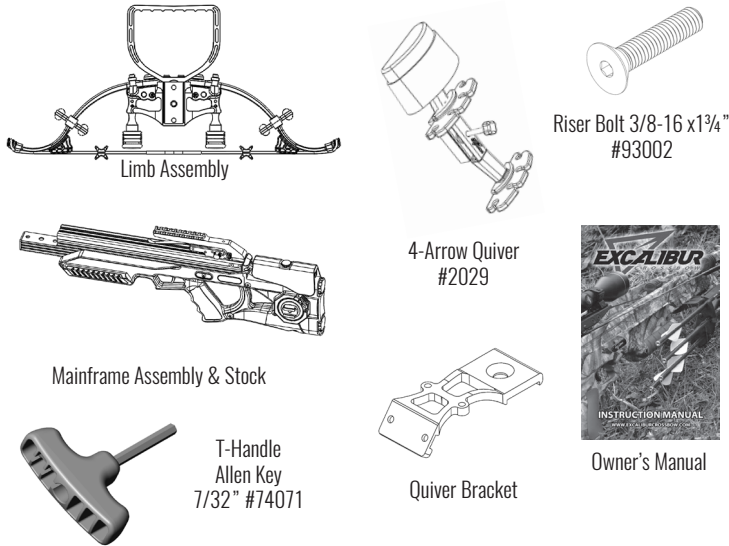

PACKAGE ALSO INCLUDES: Arrows, 100 grain field points, Excalibur Scope & Rings (pre-installed on scope)

**NOTE: SCOPE SHOULD BE MOUNTED LAST FOR EASIER CROSSBOW ASSEMBLY, REFER TO SCOPE INSTRUCTIONS INCLUDED IN THE SCOPE BOX**

### Step 2: Attach the mainframe assembly and limb assembly.

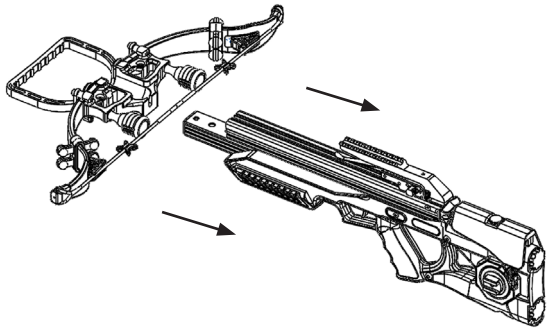

Locate and align both the mainframe and riser bolt holes as shown. Ensure Mainframe and Limb Assembly sections remain level with each other until joined. The quiver bracket can be mounted on the Left (LH shooters) or Right (RH shooters).

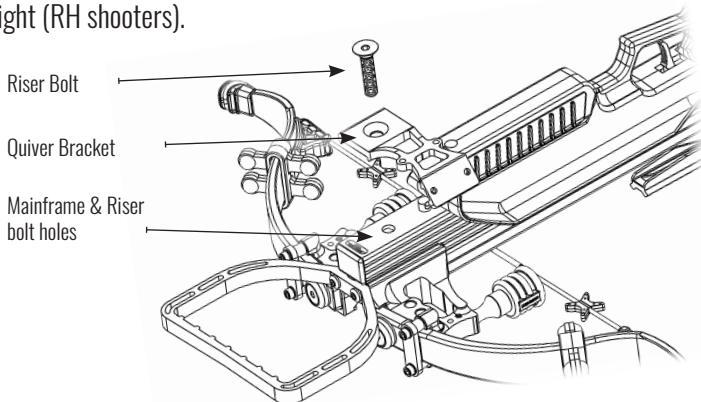

### Step 3: Secure together using the 3/8" - 16x1 3/4" Riser Bolt and T-Handle Allen Key through the quiver bracket into mainframe and riser

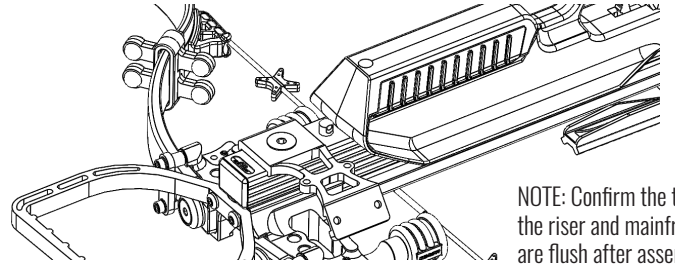

NOTE: Confirm the top of the riser and mainframe are flush after assembly

### Step 4: To install Ex-Shox, Establish correct Brace Height. (see bottom of page) Expose adhesive tape and with foot in the stirrup lightly pull back on the string. Ensure EXCALIBUR logo is facing towards the mainframe. Slide the rubber with the string in the groove until it reaches the limb. Firmly press the Ex-Shox tape onto limb. Adhesive tape should be approx. 1 5/8" from the limb tip. It is recommended to let the tape adhere for 24 hours before shooting

Correct Ex-Shox location on limb. Ensure to let Ex-Shox to adhere for 24 hours before shooting

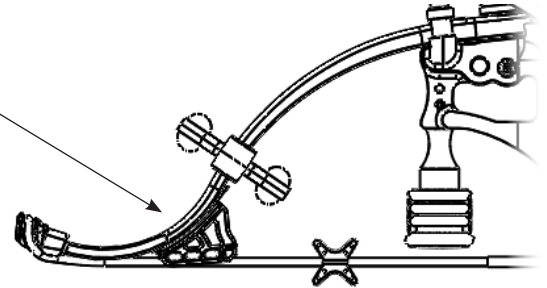

### Step 5: The quiver attaches to the quiver bracket by using a plastic receiver block (supplied). Place the two 10-24x1/2" tapered screws through the holes in the block and into the two holes located in the bracket. Secure using the two 10-24 bolts and acorn nuts. Ensure the widest part of groove is facing forward to accept the quiver. Slide the quiver into the block from the front of the crossbow and lock into place with the thumbscrew.

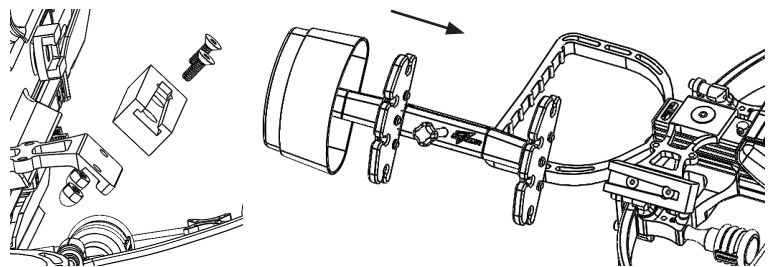

### Step 6: Install your included scope by following the included instructions in the scope box.

**BRACE HEIGHT IS MEASURED FROM THE JOINT WHERE THE RISER MEETS THE MAINFRAME TO THE CENTER OF THE STRING AND SHOULD BE 1.5" TO 2". AS A QUICK CHECK, THE STRING SHOULD SIT 1/8" TO 5/8" FROM R.E.D.S. IF INSTALLED. EXCALIBUR'S CROSSBOW STRINGER #2096 IS REQUIRED TO REMOVE THE STRING TO ADJUST BRACE HEIGHT OR CHANGE STRINGS. PLEASE CONSULT YOUR OWNER'S MANUAL FOR MORE DETAILS.**